

Rubber Tyred Wheels

BRAUER[®]



Rubber tyred wheels are the least expensive type of tyred wheel and are suitable for moderate loads. They are quiet in operation and protect the surface on which they run, although they can cause marking. Rubber tyres can generate static electricity, and where this is undesirable, 'anti-static' tyres can be specified.

MATERIAL: Wheel centre-cast iron to BS1452: 1977: Grade 200.
Tyre-carbon black reinforced natural rubber compound of 85°± 5°A Shore hardness.

OPERATING TEMPERATURE RANGE:
0°C to 50°C.

The 'maximum load rating' given for each wheel is for operation under ideal conditions. Load factors must be applied according to the anticipated working conditions – see 'Design Data' para. 3.1.

Alternative bore/bearing diameters and alternative bearing types (i.e. bronze bushes, self-lubricating bushes, roller bearings, spherical roller bearings, etc.) are available to order – see page 26-27.

For technical information covering load factors, inertial and rolling resistance, coefficients of friction between wheel and surface, and keyway dimensions, see "Design Data" Index on page 20.

Drawings show grease nipple but standard wheels do not come with grease nipple unless specifically requested.

WHEEL TYPE:
R100/40
See table for full part number

Maximum load rating:
120Kg
See page 21 for load factors
Approximate weight: 1.5Kg

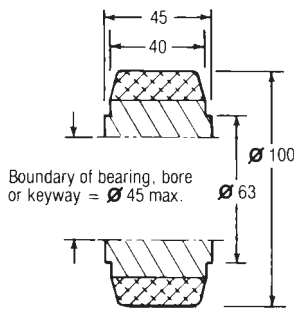

FULL PART NUMBER FOR ORDERING				
Axle Ø	Plain Bore	Plain Bore Keywayed	Ball Bearing	Taper Roller Bearing
METRIC AXLE Ø				
12	R100/40/PBM 12	R100/40/KM 12	R100/40/BJM 12	
20	R100/40/PBM 20	R100/40/KM 20	R100/40/BJM 20	
25	R100/40/PBM 25	R100/40/KM 25		

Wheels fitted with ball journals are pre-lubricated, double shielded

WHEEL TYPE:
R125/30
See table for full part number

Maximum load rating:
150Kg
See page 21 for load factors
Approximate weight: 1.5Kg

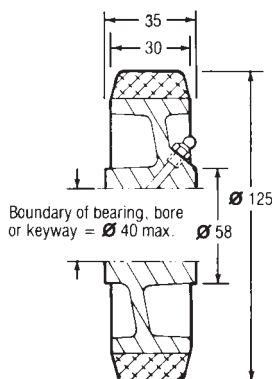

FULL PART NUMBER FOR ORDERING				
Axle Ø	Plain Bore	Plain Bore Keywayed	Ball Bearing	Taper Roller Bearing
METRIC AXLE Ø				
20	R125/30/PBM 20	R125/30/KM 20	R125/30/BJM 20	
25	R125/30/PBM 25	R125/30/KM 25		
30	R125/30/PBM 30	R125/30/KM 30		

RUBBER TYRED WHEELS

WHEEL TYPE:

R150/50

See table for full part number

Maximum load rating:

400Kg

See page 21 for load factors

Approximate weight: 3Kg

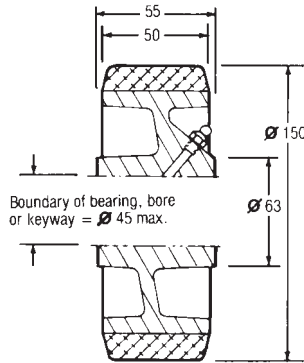

FULL PART NUMBER FOR ORDERING

Axle Ø	Plain Bore	Plain Bore Keywayed	Ball Bearing	Taper Roller Bearing
METRIC AXLE Ø				
20			R150/50/BJM 20	
25	R150/50/PBM 25	R150/50/KM 25	R150/50/BJM 25	
30	R150/50/PBM 30	R150/50/KM 30		

WHEEL TYPE:

R200/40

See table for full part number

Maximum load rating:

400Kg

See page 21 for load factors

Approximate weight: 4Kg

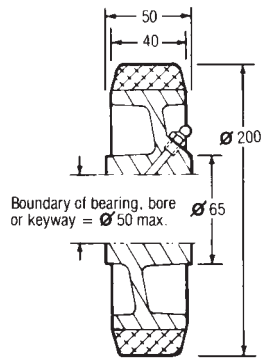

Axle Ø	Plain Bore	Plain Bore Keywayed	Ball Bearing	Taper Roller Bearing
METRIC AXLE Ø				
20			R200/40/BJM 20	
25	R200/40/PBM 25	R200/40/KM 25	R200/40/BJM 25	
30	R200/40/PBM 30	R200/40/KM 30		