

# 2500kg Jacking Unit JU2500

**BRAUER**®

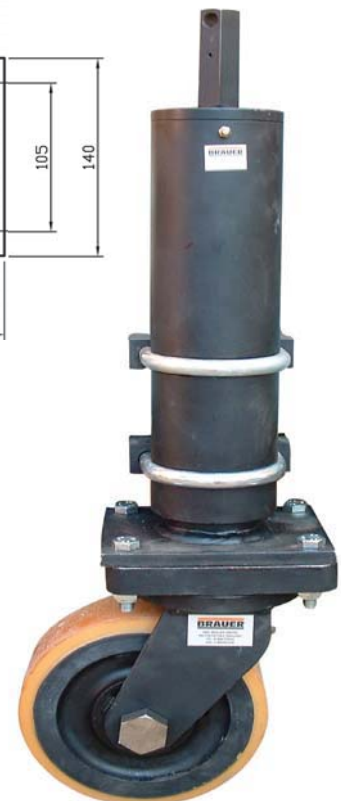
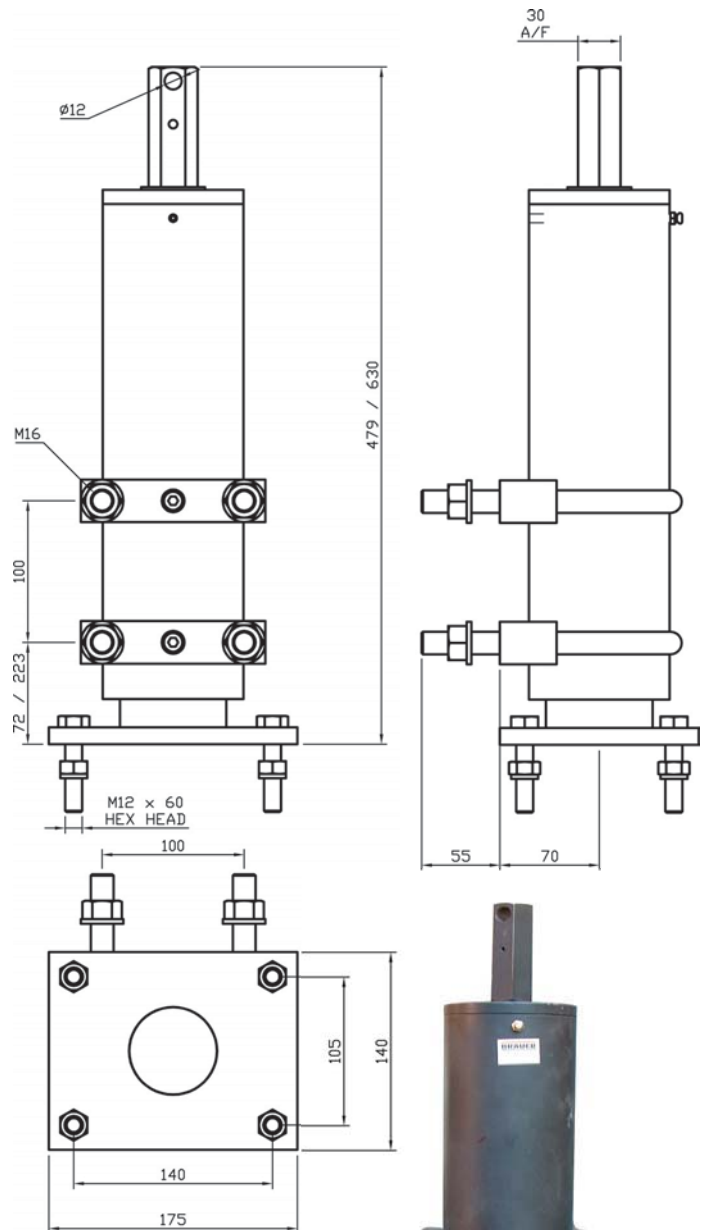

Brauer have developed a Jacking Unit, which is now available for general purchase. The Jacking unit is adaptable to many environments and applications due to our in house design team and manufacturing capability.

Many options are available due to the integration of our WG Series Castor into the design, giving unsurpassed flexibility to the market place.

Availability and delivery are enhanced because we are a leading UK manufacturer and control all aspects of the Jacking Unit.

Load rating up to 2500kg per unit.

Bespoke design which is now incorporated into our full range of wheels and castors

Robust design.

Designed to suit our WG castor range.

Wheel options from 150mm to 300mm diameter.

Swivel and fixed castor options.

Flat foot option for non castor applications.

Approximate weight 35Kg.

**2500KG JACKING UNIT**

*NOTE: Also available with other wheel types.*

## 1000kg Jacking Unit JU1000

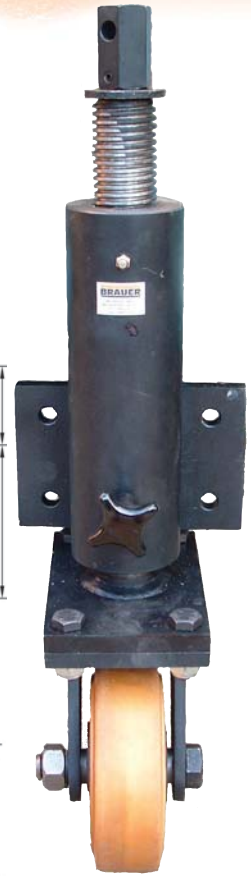
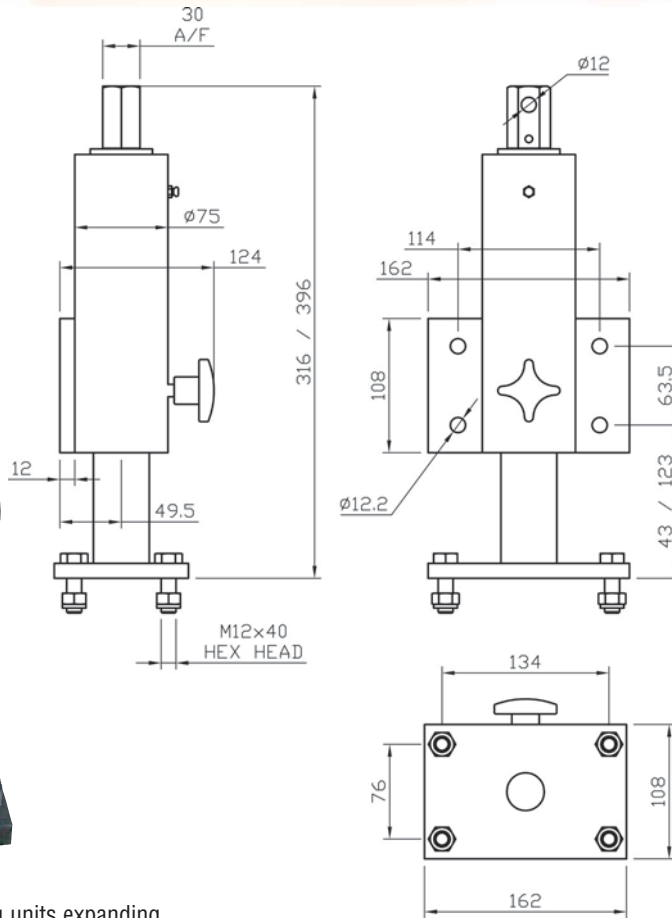

Brauer have developed a range of jacking units expanding further our comprehensive range of heavy duty castors and wheels. The jacking units are highly adaptable across a broad range of environments and applications. Many options are available giving this new product unsurpassed flexibility for the worldwide market place. Availability and delivery is enhanced due to products being totally manufactured within the wheels and castors division based in the UK. Robust design. Load rating up to 1000kg per unit. Integral swivel mechanism incorporated into jacking castor. Designed to suit our GG fixed castor. Wheel options from 100mm to 250mm diameter. Wheel options include steel, polyurethane and nylon. Jacking units now form part of Brauer comprehensive range of wheels and castors.

Approximate weight: 25Kg

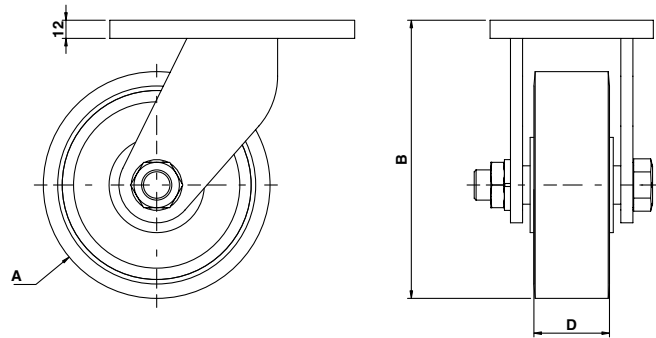

FOR TECHNICAL INFORMATION COVERING LOAD FACTORS, ETC., SEE 'DESIGN DATA' INDEX ON PAGE 20

A	B	C	D				
Wheel Diameter	Overall Height	Overall Length	Wheel Width	Max Load Rating	Wheel Bearing Type	PART NUMBER	Approx Weight kg
100	133	171	40	450	Ball Journal	JGG/H100/40BJ	8
150	184	206	50	900	Ball Journal	JGG/H150/50BJ	9
200	235	241	40	900	Ball Journal	JGG/H200/40BJ	11
250	286	276	45	1300	Ball Journal	JGG/H250/45BJ	16

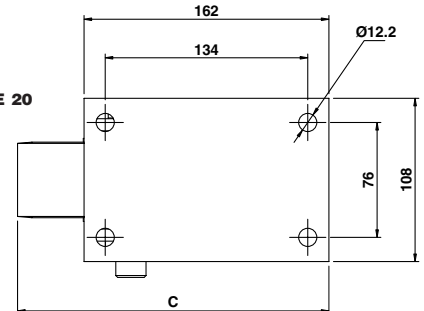

NOTE: Also available with other wheel types.