

Operating Instructions for Threaded Inserts

Installation Instructions

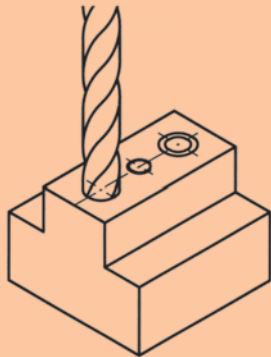

1.*
Rebore the old thread and countersink it (82°–100°)

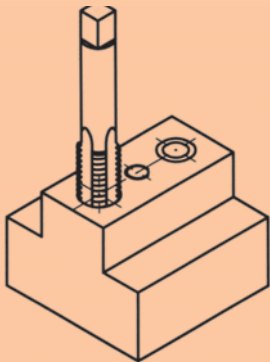

2.*
Tap planned thread with a standard screw tap

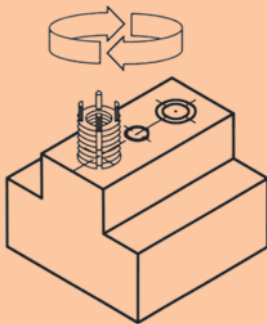

3.
Screw in the insert to just below the surface (0.3–0.7 mm)

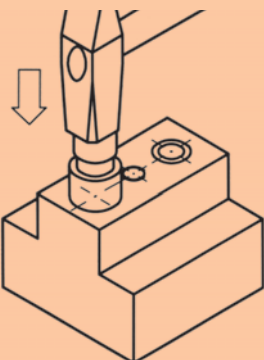

4.
Drive in the locking pins by striking the assembly tool lightly with a hammer

* For steps 1 and 2 see table under installation of threaded inserts

Removal Instructions

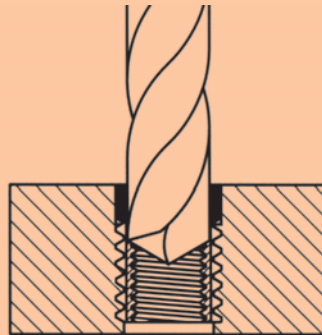

1.*
Rebore the material between the locking pins and the internal thread to the specified depth

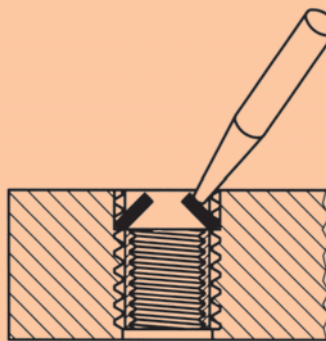

2.
Bend the locking pins inwards and break them off

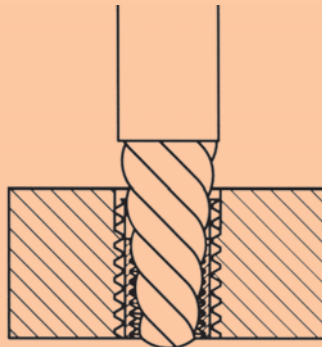

3.
Remove the old insert with a screw extractor

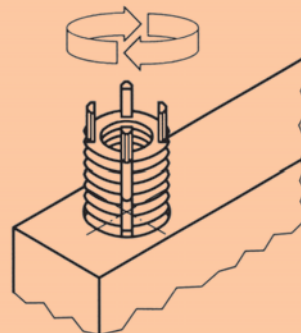

4.
Install a new threaded insert in the original threaded hole

* For step 1 see table under removal of threaded inserts

Reinforced Threaded Inserts



locking pin

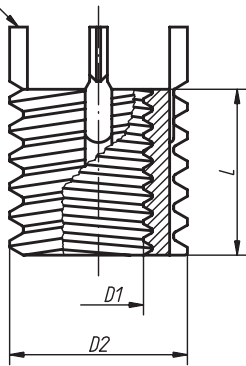

Material:

Threaded insert in hardened steel or stainless steel

Surface finish:

Phosphated

Note:

Reinforced Threaded Inserts allow threaded holes which have been damaged, torn out or jammed to be used again or repaired. This makes it possible to recover scrap and rejects of expensive products.

Reinforced Threaded Inserts are suitable for use in various materials, including light metals and castings.

Inserts with internal threads larger than M6 are supplied with four locking pins instead of two.

Permissible deviations: the medium tolerance class applies to the threads listed, i.e. 6H for nut threads and 6g for bolt threads.

Other dimensions ± 0.25 mm.

Benefits of Reinforced Threaded Inserts:

- Quick and easy installation.
- The insert is fixed with pins in order to prevent torsion due to twisting or vibrations.
- No other special tools are needed besides the installation tool.

Reinforced Threaded Inserts and Assembly Tools

Order No. steel	Order No. stainless steel	Threaded insert			Assembly tool Order No.	Installation			Removal		
		Internal thread D1	External thread D2	Length L		Drill Ø	Countersun kØ +0.25 0	Screw tap	Min. thread depth	Drill Ø	Drilling depth
07661-04	07661-104	M 4	M 8	8	07661-804	6,9	8,3	M 8	9,5	5,5	4
07661-05	07661-105	M 5	M 10 x 1,25	10	07661-805	8,8	10,3	M 10 x 1,25	12,5	7,5	4,8
07661-06	07661-106	M 6	M 12 x 1,25	12	07661-806	10,8	12,3	M 12 x 1,25	14,5	9,5	4,8
07661-08	07661-108	M 8	M 14 x 1,5	14	07661-808	12,8	14,3	M 14 x 1,5	16,5	11,5	4,8
07661-08 x 1	07661-108 x 1	M 8 x 1	M 14 x 1,5	14	07661-808	12,8	14,3	M 14 x 1,5	16,5	11,5	4,8
07661-10	07661-110	M 10	M 16 x 1,5	16	07661-810	14,8	16,3	M 16 x 1,5	18,5	13,5	4,8
07661-10 x 125	07661-110 x 125	M 10 x 1,25	M 16 x 1,5	16	07661-810	14,8	16,3	M 16 x 1,5	18,5	13,5	4,8
07661-12	07661-112	M 12	M 18 x 1,5	18	07661-812	16,8	18,3	M 18 x 1,5	20,5	15,5	4,8
07661-12 x 125	07661-112 x 125	M 12 x 1,25	M 18 x 1,5	18	07661-812	16,8	18,3	M 18 x 1,5	20,5	15,5	4,8
07661-14	07661-114	M 14	M 20 x 1,5	20	07661-814	18,8	20,3	M 20 x 1,5	22,5	17,5	4,8
07661-14 x 15	07661-114 x 15	M 14 x 1,5	M 20 x 1,5	20	07661-814	18,8	20,3	M 20 x 1,5	22,5	17,5	4,8
07661-16	07661-116	M 16	M 22 x 1,5	22	07661-816	20,7	22,3	M 22 x 1,5	24,5	17,8	6,4
07661-16 x 15	07661-116 x 15	M 16 x 1,5	M 22 x 1,5	22	07661-816	20,7	22,3	M 22 x 1,5	24,5	17,8	6,4
07661-18 x 15	07661-118 x 15	M 18 x 1,5	M 24 x 1,5	24	07661-818	22,5	24,3	M 24 x 1,5	26,5	19,8	6,4
07661-20	07661-120	M 20	M 30 x 2	30	07661-820	28	30,3	M 30 x 2	34,5	25,8	6,4
07661-20 x 15	07661-120 x 15	M 20 x 1,5	M 30 x 2	30	07661-820	28	30,3	M 30 x 2	34,5	25,8	6,4
07661-22 x 15	07661-122 x 15	M 22 x 1,5	M 32 x 2	32	07661-822	30	32,3	M 32 x 2	36,5	27,8	6,4
07661-24	07661-124	M 24	M 33 x 2	33	07661-824	31	33,3	M 33 x 2	37,5	28,8	6,4
07661-24 x 2	07661-124 x 2	M 24 x 2	M 33 x 2	33	07661-824	31	33,3	M 33 x 2	37,5	28,8	6,4

Sample order: Reinforced Threaded Insert 07661-12 / KIPP Assembly Tool 07661-812