



VERTICAL CAM CLAMPS

- **Features:**

Cam clamps are similar to vertical clamps but the clamping force is generated not by a toggle linkage, but by the action of a roller on a cam.

The cam action allows components of differing thickness to be clamped without readjustment of the clamping spindle.

Model CV75 can clamp parts with thickness varying by up to 1.5mm, and models CV250 and CV350 thickness varying by up to 2mm.

A comfortable, cushioned PVC handle grip is fitted to all three models of cam clamp.

Specification:

The main components are of zinc plated and passivated steel, the cam and its roller being case hardened to resist wear.

Rivets are of stainless steel, which burnishes and work-hardens with use, the rivets of models CV250 and CV350 rotating in hardened bushes. The setscrews are of steel with a chemi-black finish.

VERTICAL CAM CLAMPS

VERTICAL CAM CLAMPS

MODEL CV75



for front mounting use
bracket Model FM1

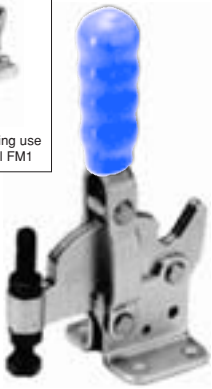

Arm:
The spindle is in a fixed position.

Base:
Flanged.

Nominal Holding Force:
75 daN

Weight:
0.05 Kg

Supplied complete with:
MB0535 Setscrew & nuts.

See "Accessories" for other items.

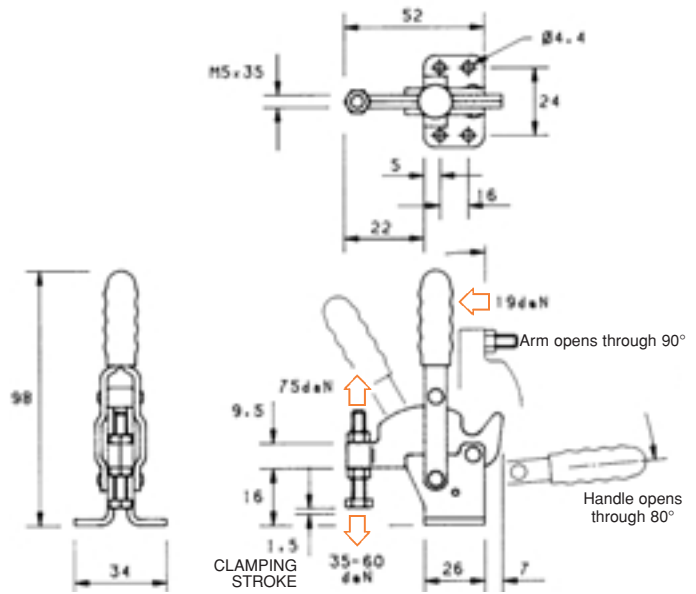

VERTICAL CAM CLAMPS

MODEL CV250



for front mounting use
bracket Model FM2

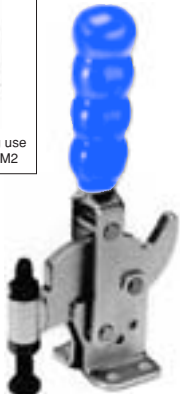

Arm:
The spindle is in a fixed position.

Base:
Flanged.

Nominal Holding Force:
250 daN

Weight:
0.35 Kg

Supplied complete with:
MB0860 Setscrew & nuts.

See "Accessories" for other items.

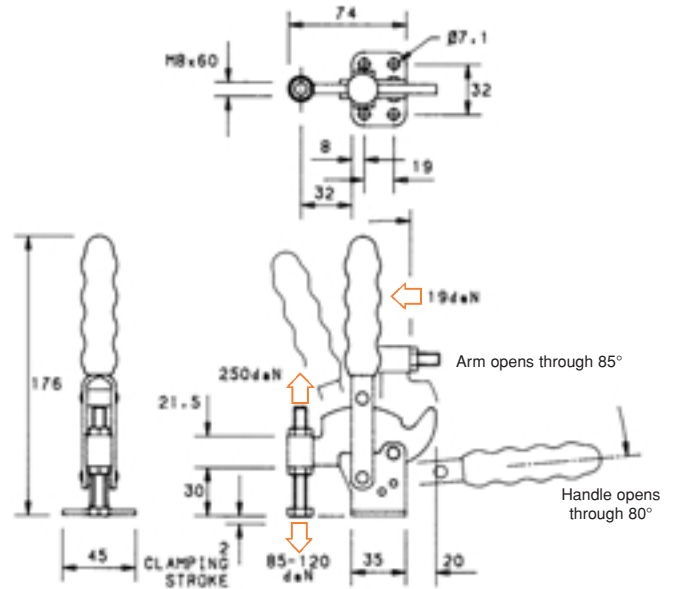

VERTICAL CAM CLAMPS

MODEL CV350



for front mounting use
bracket Model FM3

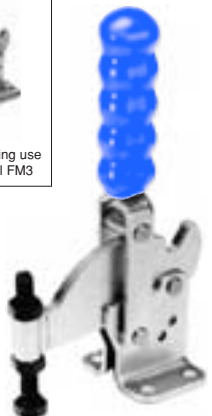

Arm:
The spindle is in a fixed position.

Base:
Flanged.

Nominal Holding Force:
350 daN

Weight:
0.70 Kg

Supplied complete with:
MB1080 Setscrew & nuts.

See "Accessories" for other items.

