



## MAGNA FORCE HEAVY DUTY CAM CLAMPS

- Unique, patented range of cam clamps
- Rugged build quality, ideal for machine shops
- Clamping forces from 300 daN to 5000 daN
- Significant cost benefits over strap clamps in repetitive machining
- A fraction of the cost of hydraulic workholding

## MAGNA FORCE HEAVY-DUTY CAM CLAMPS

### CAM RAM CLAMPS

MODELS **CR4000** (CLOCKWISE)

**CR4000A** (ANTI-CLOCKWISE)



**Operating clamping force:**  
750 daN (hand applied),  
4000 daN (mallet applied)  
**Weight:**  
0.55 Kg

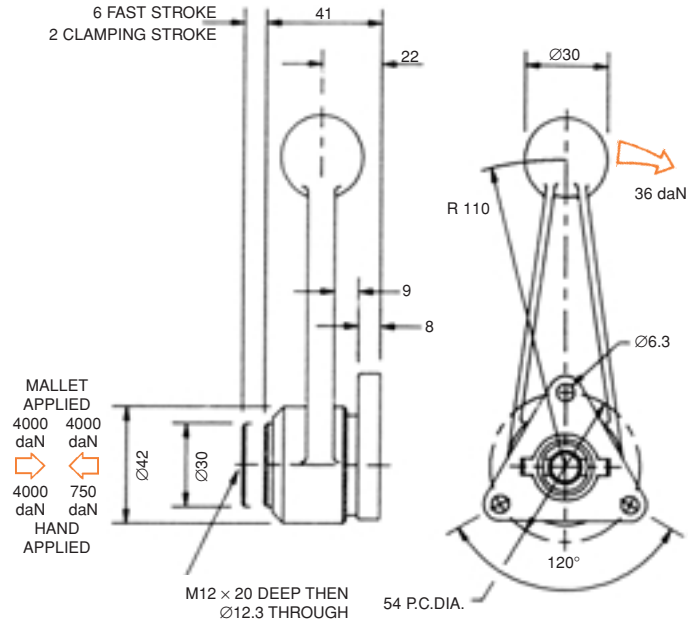

### CAM RAM CLAMPS

MODELS **CR5000** (CLOCKWISE)

**CR5000A** (ANTI-CLOCKWISE)



**Operating clamping force:**  
850 daN (hand applied),  
5000 daN (mallet applied)  
**Weight:**  
1.3 Kg

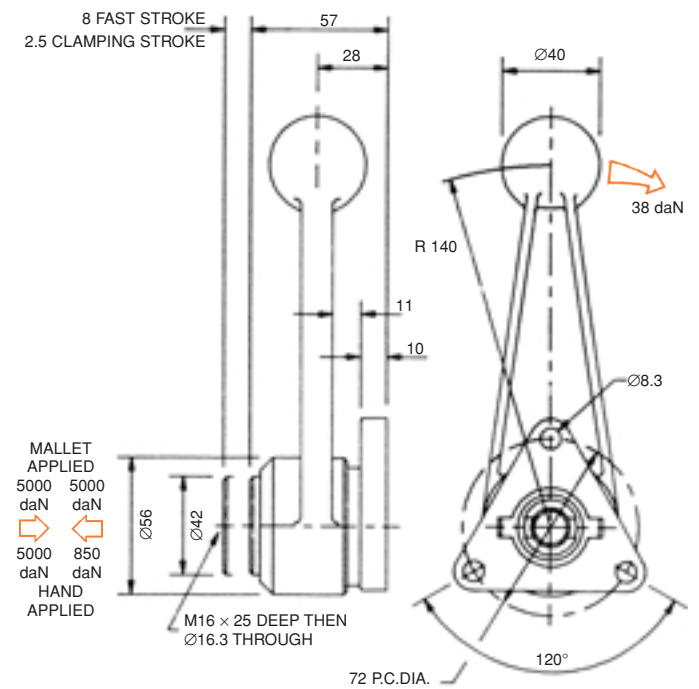

#### TECHNICAL INFORMATION

Clamp No.	Applied Handle Force (Hand Push)	Clamping Force	Clamping Force using Mallet Blows	Daylight Travel	Clamping Travel
<b>CR4000</b>	36 daN	750 daN	4000 daN	6.0mm	2.0mm
<b>CR4000A</b>	36 daN	750 daN	4000 daN	6.0mm	2.0mm
<b>CR5000</b>	38 daN	850 daN	5000 daN	8.0mm	2.5mm
<b>CR5000A</b>	38 daN	850 daN	5000 daN	8.0mm	2.5mm

## MAGNA FORCE HEAVY-DUTY CAM CLAMPS

### CAM SWING CLAMPS

MODELS **CS300** (CLOCKWISE)

**CS300A** (ANTI-CLOCKWISE)

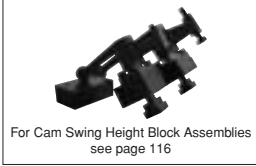

**Operating clamping force:**  
300 daN (hand applied).  
**Weight:**  
0.20 Kg  
**Supplied complete with:**  
MB0625 Set screw & nuts.

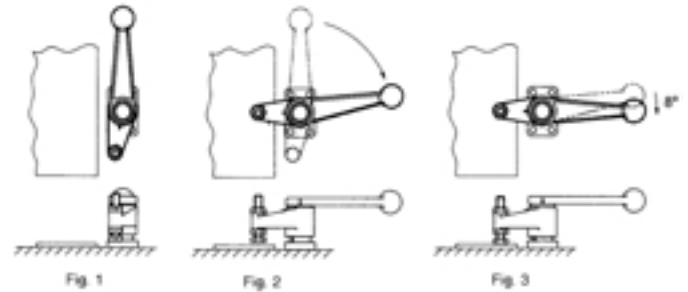
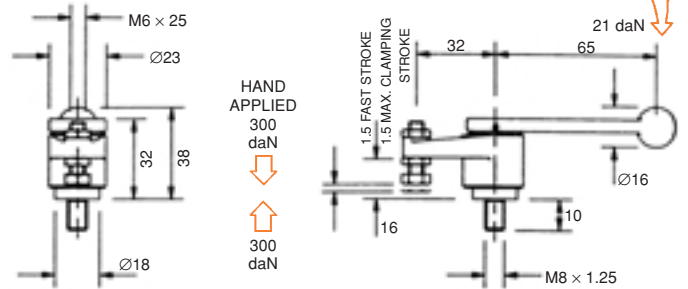
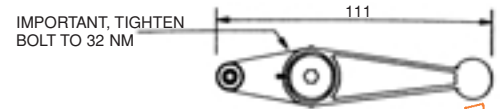

### CAM SWING CLAMPS

MODELS **CS800** (CLOCKWISE)

**CS800A** (ANTI-CLOCKWISE)

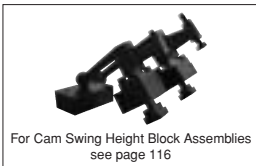

**Operating clamping force:**  
500 daN (hand applied),  
800 daN (mallet applied).  
**Weight:**  
0.40 Kg  
**Supplied complete with:**  
MB0840 Set screw & nuts.

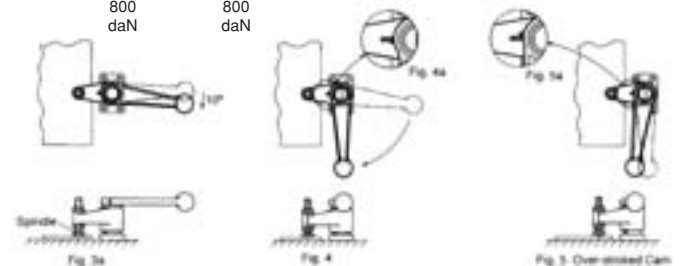
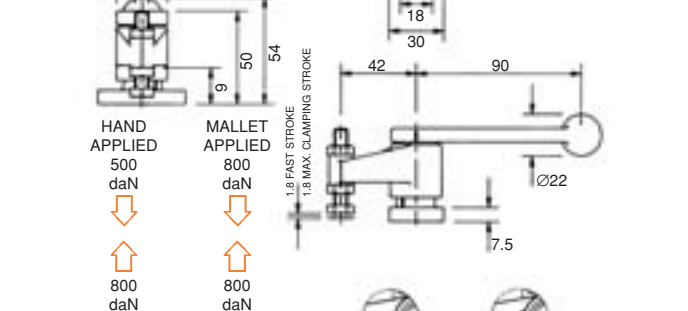
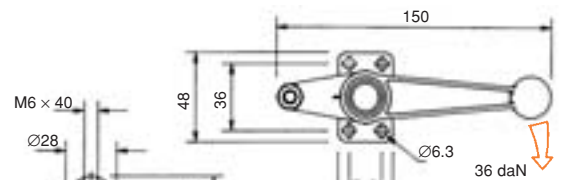

#### TECHNICAL INFORMATION

Clamp No.	Applied Handle Force (Hand Push)	Clamping Force	Clamping Force using Mallet Blows	Daylight Travel	Clamping Travel
CS300	21 daN	300 daN	N/A	1.5mm	1.5mm
CS300A	21 daN	300 daN	N/A	1.5mm	1.5mm
CS800	36 daN	500 daN	800 daN	1.8mm	1.8mm
CS800A	36 daN	500 daN	800 daN	1.8mm	1.8mm

## MAGNA FORCE HEAVY-DUTY CAM CLAMPS

### CAM SWING CLAMPS

MODELS CS1200 (CLOCKWISE)

CS1200A (ANTI-CLOCKWISE)

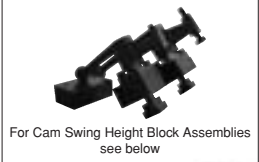

**Operating clamping force:**  
600 daN (hand applied),  
1200 daN (mallet applied).

**Weight:**  
0.90 Kg

**Supplied complete with:**  
MB1055 Set screw & nuts.

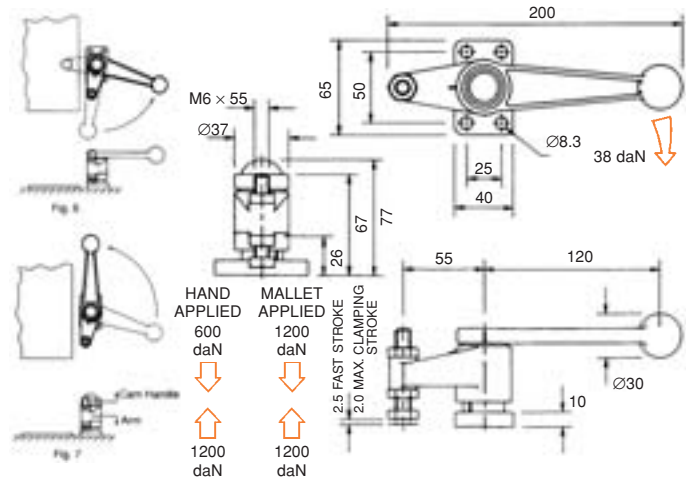

### CAM SWING HEIGHT BLOCK ASSEMBLIES

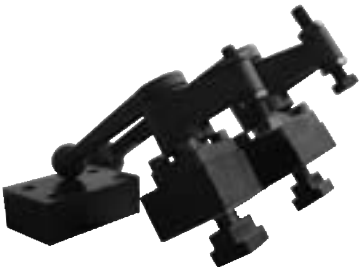

The height block assembly provides the user with a convenient method of setting the height of the Cam Swing Clamp when in operation. The act of locking the clamp onto the work piece also locks the block into position along the Tee Slot.

**Note:**  
Clamp ordered separately

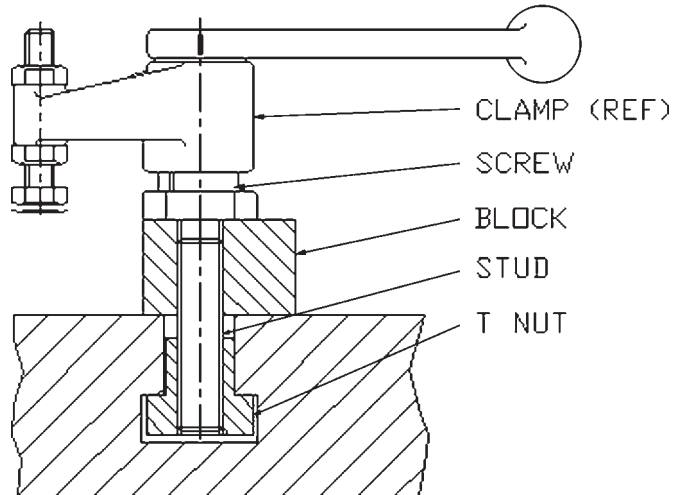

Example Part Code:

CSB1200-20-TN12

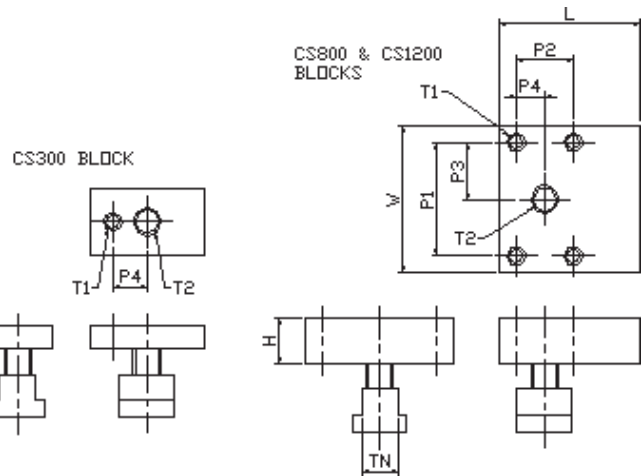
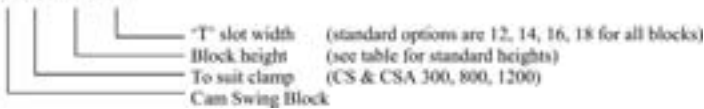

To Suit Clamp	H	W	L	TN	P1	P2	P3	P4	T1	T2	Screw ×4
CS300	10, 20, 30, 40, 50	30	50	12, 14, 16, 18	N/A	N/A	N/A	15	M8×1.25	M12×1.25	N/A
CS800	12, 25, 40, 50	48	40	12, 14, 16, 18	36	18	18	9	M6×1.0	M12×1.25	M6×18
CS1200	20, 40, 60, 76	65	62	12, 14, 16, 18	50	25	25	12.5	M8×1.25	M12×1.25	M8×25

## MAGNA FORCE HEAVY-DUTY CAM CLAMPS

### CAM PUSH CLAMPS MODELS CP1500



**Operating clamping force:**  
1500 daN (mallet applied),  
600 daN (hand applied).

**Weight:**  
0.27 Kg

**Supplied complete with:**  
MB063 Set screw & nuts.

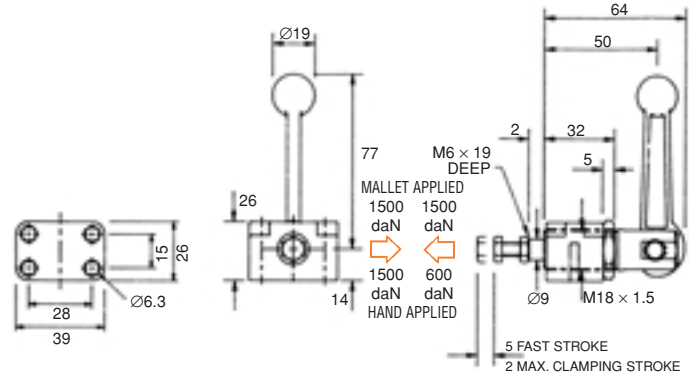

### CAM PUSH CLAMPS MODELS CP2000



**Operating clamping force:**  
2000 daN (mallet applied),  
650 daN (hand applied).

**Weight:**  
0.60 Kg

**Supplied complete with:**  
MB0840 Set screw & nuts.  
CMB24 Mounting base & locknuts.

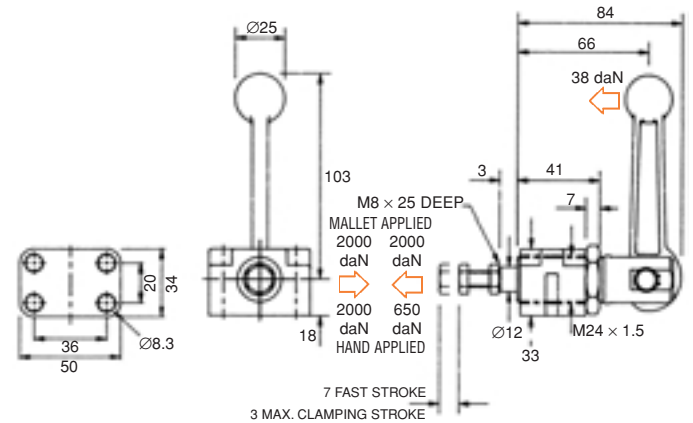

#### TECHNICAL INFORMATION

Clamp No.	Applied Handle Force (Hand Push)	Clamping Force	Clamping Force using Mallet Blows	Daylight Travel	Clamping Travel
CS1200	38 daN	600 daN	1200 daN	2.5mm	2.0mm
CS1200A	38 daN	600 daN	1200 daN	2.5mm	2.0mm
CP1500	36 daN	600 daN	1500 daN	5.2mm	2.2mm
CP2000	38 daN	650 daN	2000 daN	7.0mm	3.0mm

### CAM PUSH CLAMPS MODELS CP3000



**Operating clamping force:**  
3000 daN (mallet applied),  
650 daN (hand applied).

**Weight:**  
1.50 Kg

**Supplied complete with:**  
MB0840 Set screw & nuts.  
CMB33 Mounting base & locknuts.

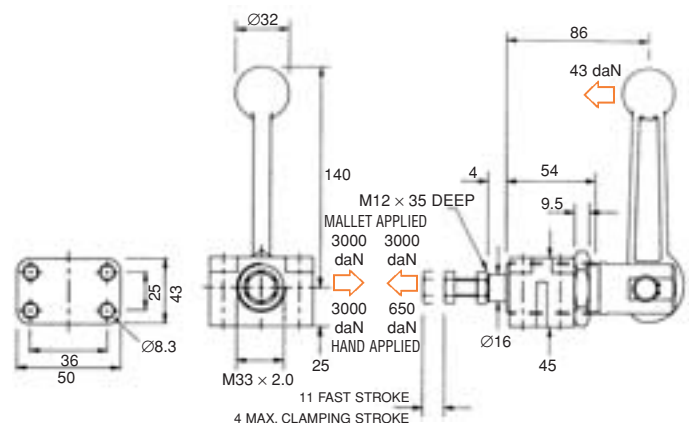

## MAGNA FORCE HEAVY-DUTY CAM CLAMPS

### CAM PUSH CLAMPS MODELS CP1500L



**Operating clamping force:**  
1500 daN  
**Weight:**  
0.35 Kg  
**Supplied complete with:**  
MB0840 Set screw & nuts.  
CMB18 Mounting base & locknuts.

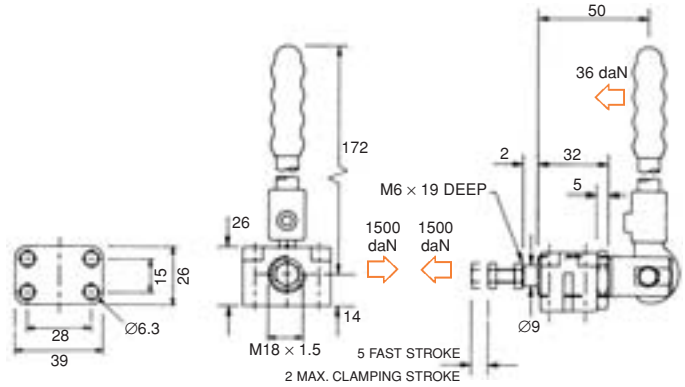

### CAM PUSH CLAMPS MODELS CP2000L



**Operating clamping force:**  
1700 daN  
**Weight:**  
0.75 Kg  
**Supplied complete with:**  
MB0840 Set screw & nuts.  
CMB24 Mounting base & locknuts.  
**Nominal holding force:**  
2000 daN

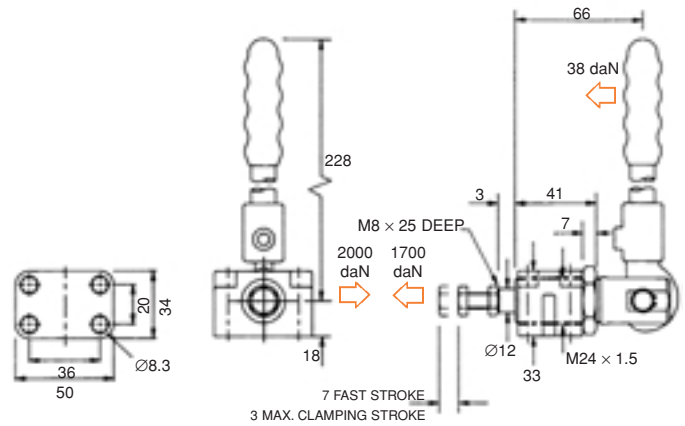

#### TECHNICAL INFORMATION

Clamp No.	Applied Handle Force (Hand Push)	Clamping Force	Clamping Force using Mallet Blows	Daylight Travel	Clamping Travel
CP3000	43 daN	650 daN	3000 daN	11.0mm	4.0mm
CP1500L	36 daN	1500 daN	N/A	5.2mm	2.2mm
CP2000L	38 daN	1700 daN	N/A	7.0mm	3.0mm

### CAM PUSH CLAMPS MODELS CP3000L



**Operating clamping force:**  
2000 daN  
**Weight:**  
2.00 Kg  
**Supplied complete with:**  
MB1250 Set screw & nuts.  
CMB33 Mounting base & locknuts.  
**Nominal holding force:**  
3000 daN

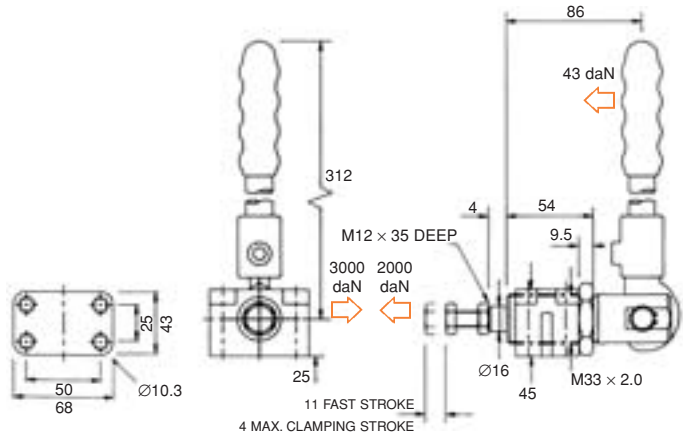

#### TECHNICAL INFORMATION

Clamp No.	Applied Handle Force (Hand Push)	Clamping Force	Clamping Force using Mallet Blows	Daylight Travel	Clamping Travel
CP3000L	43 daN	2000 daN	N/A	11.0mm	4.0mm