

TOGGLE HAND PRESSES

TOGGLE HAND PRESSES

MODEL P2500PR



DATA

With 17 daN handle force the output force is:

daN	mm
1000	Fully retracted
100	10 mm extended
72	20 mm "
60	30 mm "
70	40 mm "
88	50 mm "
118	60 mm "
190	70 mm "
230	72 mm "
353	74 mm "
1100	Fully extended

Type:
Bench mounted manual toggle press.

Nominal holding force:
2500 daN.

Weight:
15.50 kg.

Quality Features:

- S.G. Iron framecasting.
- precision ground steel plunger.
- fixed height work head.

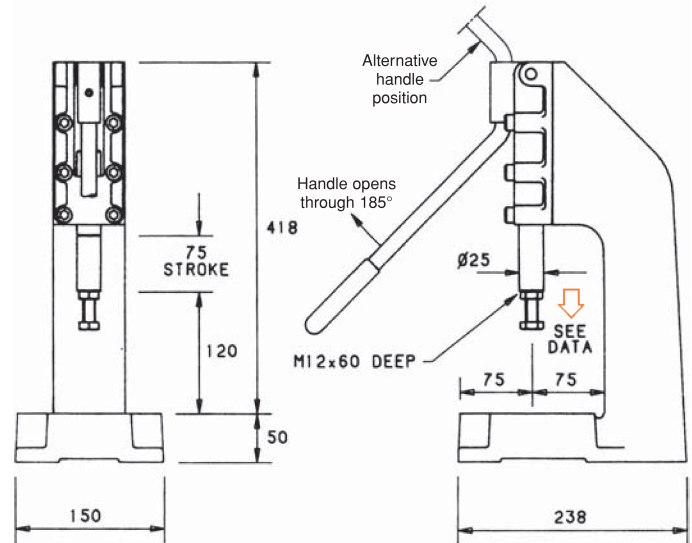
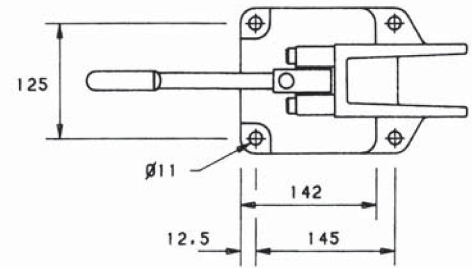

TOGGLE HAND PRESSES

MODEL TPR 1



DATA

With 13 daN handle force the output force is:

daN	mm
48	Fully retracted
45	5 mm extended
42	10 mm "
42	15 mm "
45	20 mm "
49	25 mm "
54	30 mm "
75	35 mm "
102	38 mm "
143	39 mm "
500	Fully extended

Optional Extras: please mention when ordering
Table Bore 12^{H7} mm TB
Stroke Counter Z

Type:
Bench mounted toggle press

Nominal holding force:
500 daN

Weight:
10 kg

Quality Features:

- hardened, ground ram.
- long-design, honed ram.
- ground table, with T-slot.
- adjustable working head height.

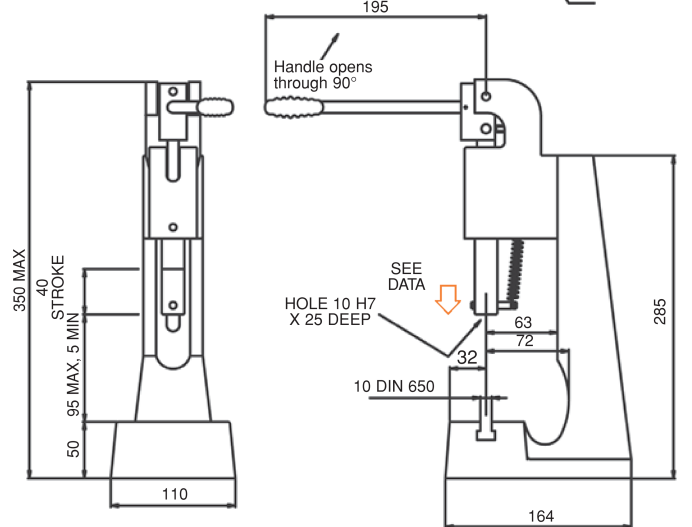
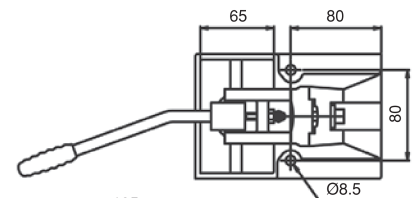

TOGGLE HAND PRESSES

TOGGLE HAND PRESSES

MODEL TPR 2

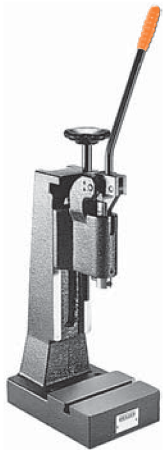

DATA

With 15 daN handle force the output force is:	daN
Fully retracted	76
5 mm extended	74
10 mm "	65
15 mm "	65
20 mm "	72
25 mm "	80
30 mm "	98
35 mm "	125
38 mm "	200
39 mm "	255
Fully extended	750

Optional Extras: please mention when ordering
 Table Bore 12^{H7}mm TB Z
 Stroke Counter Z

Type:
 Bench mounted toggle press

Nominal holding force:
 750 daN

Weight:
 19 kg

Quality Features:

- hardened, ground ram.
- long-design, honed ram.
- ground table, with T-slot.
- adjustable working head height.

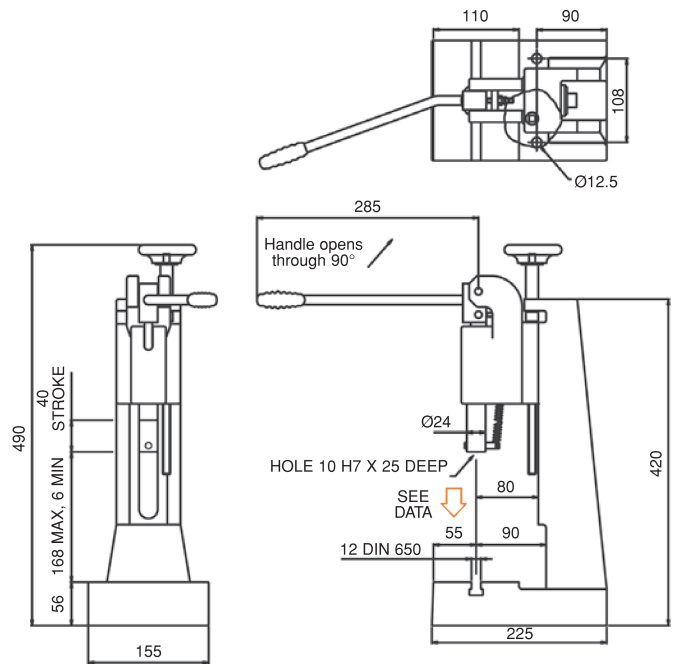

TOGGLE HAND PRESSES

MODEL TPR 3



DATA

With 20 daN handle force the output force is:	daN
Fully retracted	145
5 mm extended	135
10 mm "	130
15 mm "	130
20 mm "	130
25 mm "	140
30 mm "	160
35 mm "	230
38 mm "	325
39 mm "	440
Fully extended	1400

Optional Extras: please mention when ordering
 Table Bore 12^{H7} mm TB Z
 Stroke Counter Z

Type:
 Bench mounted toggle press

Nominal holding force:
 1400 daN

Weight:
 39 kg

Quality Features:

- hardened, ground ram.
- long-design, honed ram.
- ground table, with T-slot.
- adjustable working head height.

The **extra powerful** hand toggle presses in the TPR 3 series are especially suited to the often changing demands found in tool making and general workshops. Their high capacity up to 15 kN allow for flexible use in various applications.

