

Cam levers

with internal thread and external thread, steel or stainless steel



Material, surface finish:

Handle in cast aluminium EN AC-46200, black powder-coated;
 thrust washer in glass-fibre reinforced plastic PA 66 GF 35-X, black;
 hinge pin in stainless steel 1.4305, natural finish;
 threaded stud and washer in steel, quality class 5.8, blue chromated or stainless steel 1.4305, natural finish

Sample order:

K0005.101105X20 (please also indicate dimension L)

Note:

Plastics are characterized by creeping under load (retardation).

Cam lever with internal thread

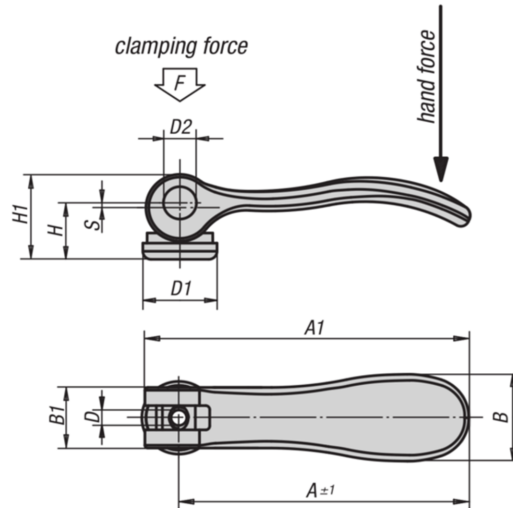

Cam lever with external thread

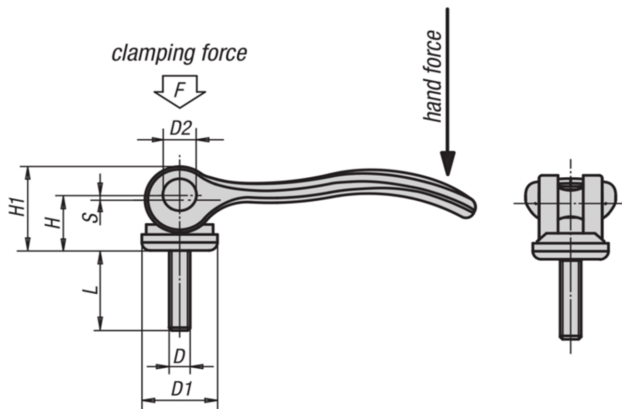

KIPP Cam levers with internal thread

| Order No. Steel | Order No. Stainless steel | Size | Internal thread D | D1 | D2 | B | B1 | H | H1 | A | A1 | Clamping force F (kN) | Hand force N | Stroke S |
|-----------------|---------------------------|------|-------------------|------|----|------|------|------|------|------|------|-----------------------|--------------|----------|
| K0005.9501103 | K0005.9511103 | 9 | M3 | 12 | 6 | 14,4 | 11,5 | 9 | 13 | 36,2 | 41,7 | 1,5 | 90 | 1 |
| K0005.9501104 | K0005.9511104 | 9 | M4 | 12 | 6 | 14,4 | 11,5 | 9 | 13 | 36,2 | 41,7 | 1,5 | 90 | 1 |
| K0005.0501104 | K0005.0511104 | 0 | M4 | 15,5 | 8 | 18 | 13 | 11,2 | 17 | 52,3 | 59 | 2,5 | 100 | 1 |
| K0005.0501105 | K0005.0511105 | 0 | M5 | 15,5 | 8 | 18 | 13 | 11,2 | 17 | 52,3 | 59 | 2,5 | 100 | 1 |
| K0005.101105 | K0005.111105 | 1 | M5 | 18 | 9 | 21,5 | 15 | 14,5 | 22 | 70,4 | 79,2 | 4 | 120 | 1,2 |
| K0005.101106 | K0005.111106 | 1 | M6 | 18 | 9 | 21,5 | 15 | 14,5 | 22 | 70,4 | 79,2 | 4 | 120 | 1,2 |
| K0005.201108 | K0005.211108 | 2 | M8 | 27 | 11 | 33,2 | 24 | 18 | 28,5 | 96 | 108 | 8 | 350 | 1,5 |

KIPP Cam levers with external thread

| Order No. steel | Order No. stainless steel | Size | External thread D | Clamping force F (kN) | Hand force N | Stroke S | L = screw length |
|-----------------|---------------------------|------|-------------------|-----------------------|--------------|----------|------------------|
| K0005.9501103X | K0005.9511103X | 9 | M3 | 1,5 | 90 | 1 | 10/15/30 |
| K0005.9501104X | K0005.9511104X | 9 | M4 | 1,5 | 90 | 1 | 10/15/30 |
| K0005.0501104X | K0005.0511104X | 0 | M4 | 2,5 | 100 | 1 | 15/20/30 |
| K0005.0501105X | K0005.0511105X | 0 | M5 | 2,5 | 100 | 1 | 20/30/40/50 |
| K0005.101105X | K0005.111105X | 1 | M5 | 4 | 120 | 1,2 | 20/30/40/50 |
| K0005.101106X | K0005.111106X | 1 | M6 | 4 | 120 | 1,2 | 20/30/40/50 |
| K0005.201108X | K0005.211108X | 2 | M8 | 8 | 350 | 1,5 | 25/30/40/50 |
| K0005.201110X | K0005.211110X | 2 | M10 | 8 | 350 | 1,5 | 25/30/40/50 |