

## VERTICAL CLAMPS

### V75 SERIES

#### MODEL V75/1B



**Arm:**  
The spindle position is adjustable along the arm.

**Base:**  
Straight.

**Nominal Holding Force:**  
75 daN

**Weight:**  
0.05 Kg

**Supplied complete with:**  
MB0535 Setscrew & nuts.  
NC/05 Neoprene cover.  
FW05/10 Flanged washers.  
See "Accessories" for other items.

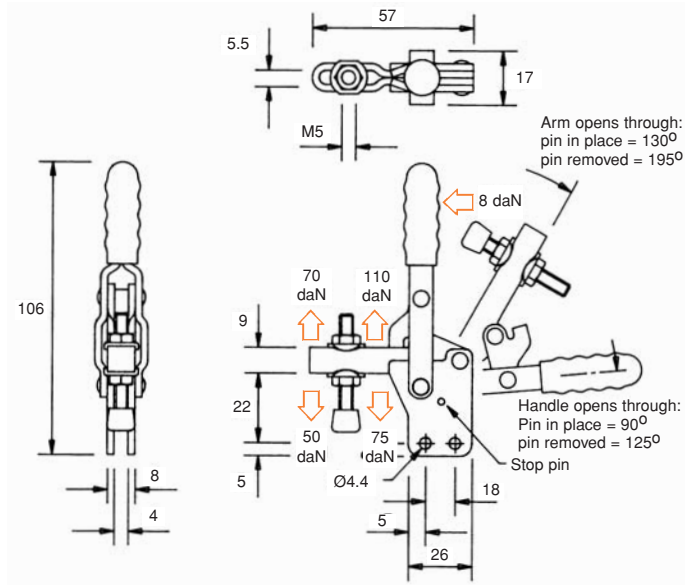

### V75 SERIES

#### MODEL V75/1BSS



**Arm:**  
The spindle position is adjustable along the arm.

**Base:**  
Straight.

**Nominal Holding Force:**  
75 daN

**Weight:**  
0.05 Kg

**Supplied complete with:**  
MB0535 Setscrew & nuts.  
NC/05 Neoprene cover.  
FW05/10 Flanged washers.

**Material:** BS 304 S15

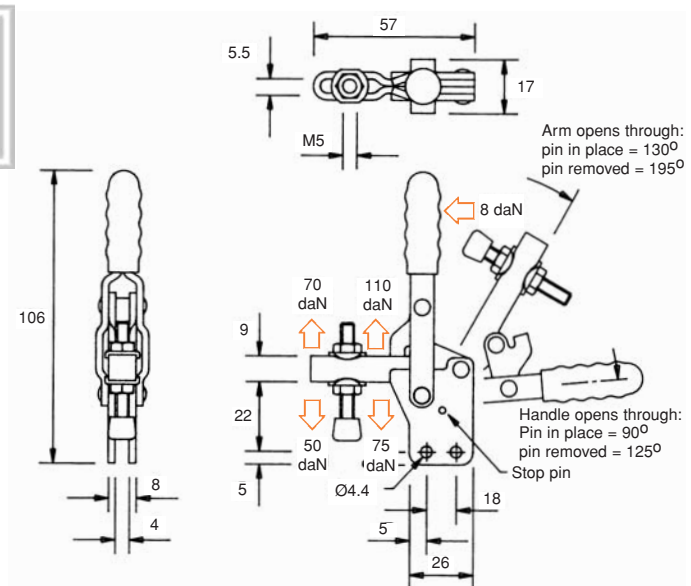

### V75 SERIES

#### MODEL V75/2B



for front mounting use bracket Model FM1



**Arm:**  
The spindle position is adjustable along the arm.

**Base:**  
Flanged.

**Nominal Holding Force:**  
75 daN

**Weight:**  
0.05 Kg

**Supplied complete with:**  
MB0535 Setscrew & nuts.  
NC/05 Neoprene cover.  
FW05/10 Flanged washers.

See "Accessories" for other items.

