

## VERTICAL CLAMPS

### V100 SERIES MODEL V100/3C



**Arm:**  
The spindle is in a fixed position.

**Base:**  
Front mounting.

**Nominal Holding Force:**  
100 daN

**Weight:**  
0.11 Kg

**Supplied complete with:**  
MB0535 Setscrew & nuts.  
NC/05 Neoprene cover.

See "Accessories" for other items.

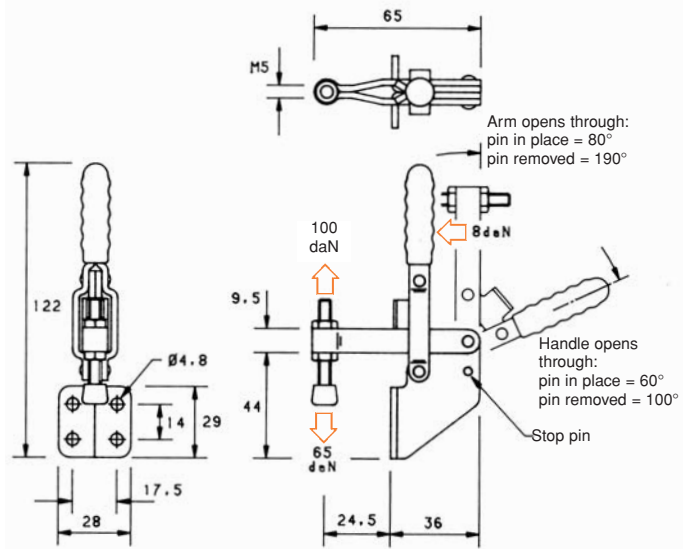

### V150 SERIES MODEL V150/1B



**Arm:**  
The spindle position is adjustable along the arm.

**Base:**  
Straight.

**Nominal Holding Force:**  
150 daN

**Weight:**  
0.15 Kg

**Supplied complete with:**  
MB0650 Setscrew & nuts.  
NC/06 Neoprene cover.  
FW06/12 Flanged washers.

See "Accessories" for other items.

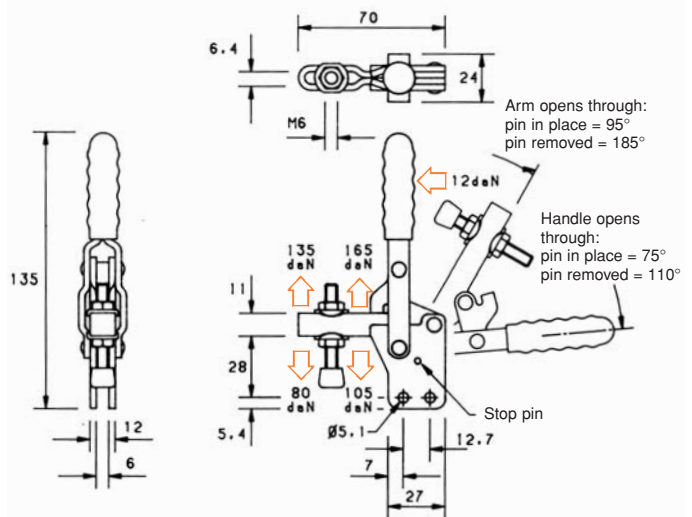

### V150 SERIES MODEL V150/1BL



**Arm:**  
The spindle position is adjustable along the arm. 15mm added to arm length over V150/1B model.

**Base:**  
Straight.

**Nominal Holding Force:**  
150 daN

**Weight:**  
0.15 Kg

**Supplied complete with:**  
MB0650 Setscrew & nuts.  
NC/06 Neoprene cover.  
FW06/12 Flanged washers.

See "Accessories" for other items.

