

PUSH-PULL CLAMPS

P100 SERIES MODEL P100



Plunger:
Locks at both extended & retracted ends of the stroke.

Base:
Nose or flange mounting.

Nominal Holding Force:
100 daN

Weight:
0.15 Kg

Supplied complete with:
MB0625 Setscrew & nut.
Mounting bracket & locknut.

See "Accessories" for alternative FM16 Mounting Bracket & other items.

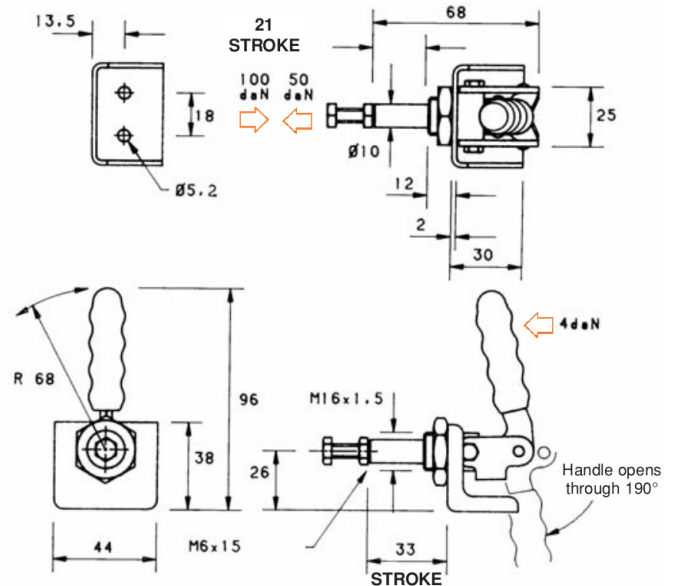

P100 SERIES MODEL P100SS



Plunger:
Locks at both extended & retracted ends of the stroke.

Base:
Nose or flange mounting.

Nominal Holding Force:
100 daN

Weight:
0.15 Kg

Supplied complete with:
Setscrew & nut.

Material:
BS 304 S15

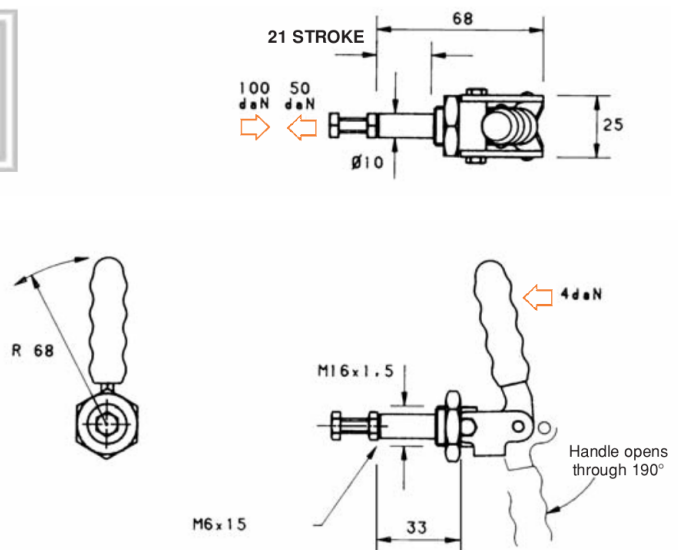

P200 SERIES MODEL P200



Plunger:
Locks at both extended & retracted ends of the stroke.

Base:
Nose or flange mounting.

Nominal Holding Force:
200 daN

Weight:
0.35 Kg

Supplied complete with:
MB0840 Setscrew & nut.
Mounting bracket & locknut.

See "Accessories" for alternative FM20 Mounting Bracket & other items.

